

$$(-\text{静圧}) + (-\text{速度圧}) + (-\text{圧損}) = -\text{全圧}$$

$$(\text{静圧}) + (\text{速度圧}) + (\text{圧損}) = \text{全圧}$$

計算順

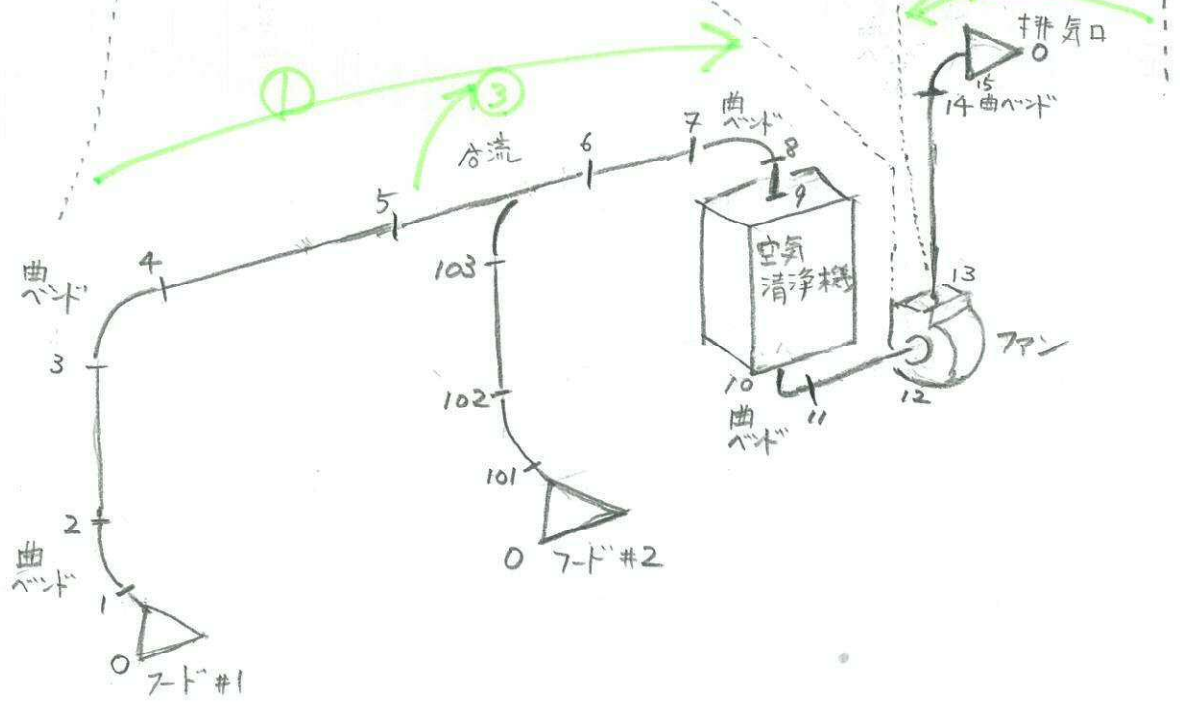

系統線図

